



Road Warrior Camper, Owner's Manual

Congratulations on your new Road Warrior Camper!

Please read the following manual and follow all safety, user, and maintenance instructions.

TERMINOLOGY: Road Warrior Camper: RWC

SAFETY INSTRUCTIONS AND WARNINGS:

1. Follow all road rules and road signs when towing your RWC.
2. Do not drink and drive and tow.
3. Ensure all equipment and cargo is securely fastened within and on the trailer.
4. After 100km of driving check all threaded fasteners.
Road vibrations and noise can loosen fasteners, especially in extreme weather conditions of high and low temperatures.
5. Roof Top Tents that are attached to the RWC Lift Frame of the RWC Adventurer should be attached following the Roof Top Tent manufacturer's instructions. Check all roof top tent fasteners regularly to ensure reliable and safe operation.
6. Do not manually shift the RWC with the Lift Frame in the raised position.
7. Do not tow the RWC with the Lift Frame in the raised position.
8. When packing the RWC for travel distribute the cargo and items evenly to prevent unsafe conditions at high speeds.
 - a. Place heavy items over the axles.
9. Always ensure the lock pins and thumb screws are securely in place for towing and after operating Lift Frame.
10. Ensure the four Stabilising Feet are lowered and extended when raising the Lift Frame for setting camp, or for climbing into the Roof Top tent for any purpose.
11. Check the 7 Pin Trailer Connection before connecting to the vehicle and ensure all trailer lights are working correctly before towing.

12. Do not stand on any part of the RWC, this includes any part of the chassis, tow bar, boxes and mudguards.

13. Do not stand or climb on the Lift Frame.

14. The RWC is for stowage and transport of cargo and items only. Enclosed spaces of the RWC are not suitable for humans or pets.

- a. Do not sleep within the RWC
- b. Do not travel within the RWC
- c. Do not ride on the RWC when towing or shifting.

SPECIFICATIONS: Images may differ from actual product

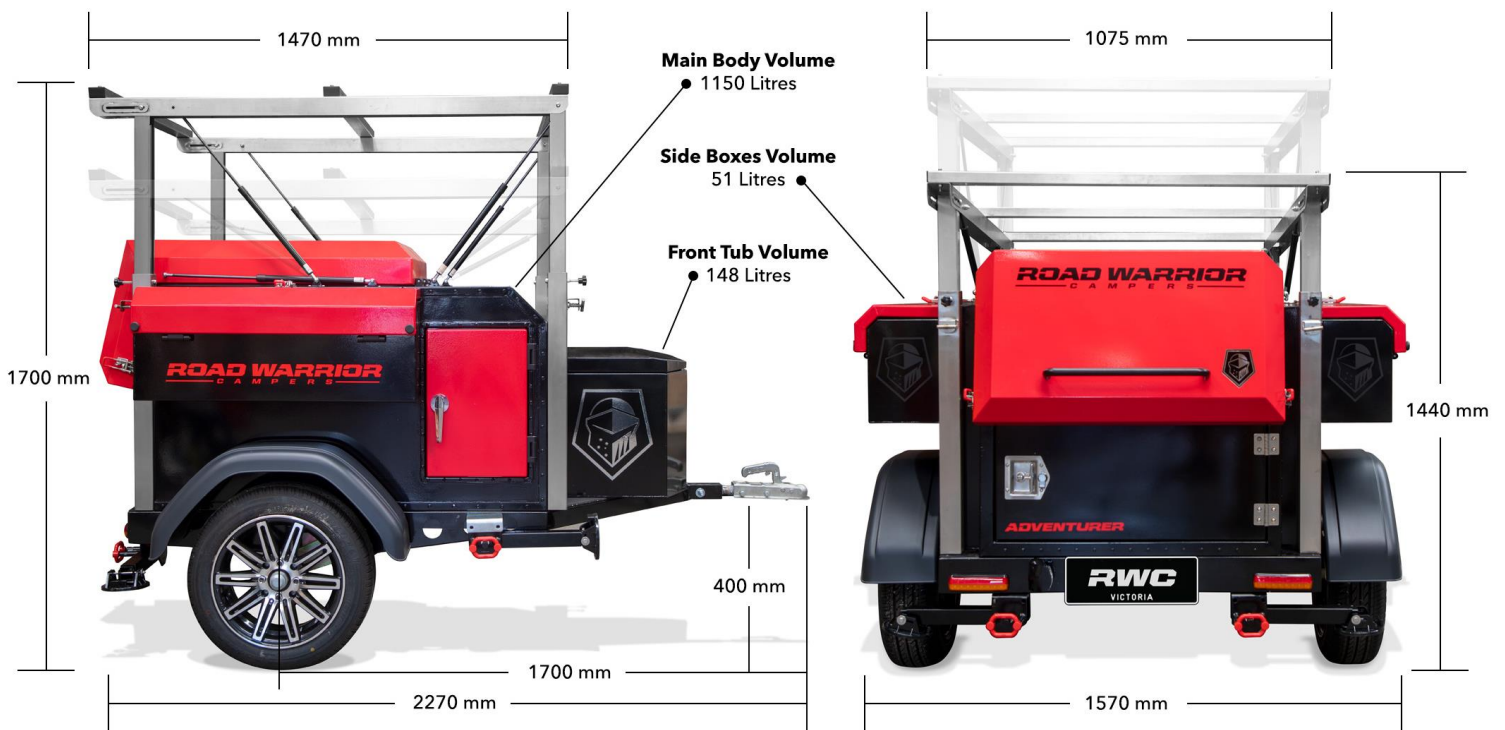

1. Specifications

Make: Impact Import Group Pty. Ltd. Road Warrior Camper, Trailer

Model: Adventurer 1.0

Trailer Classification: TA TARE (Kg) ~ 230

Aggregate Trailer Mass, ATM (Kg) 600

Gross Trailer Mass, GTM (Kg) ~550

USER INSTRUCTIONS:

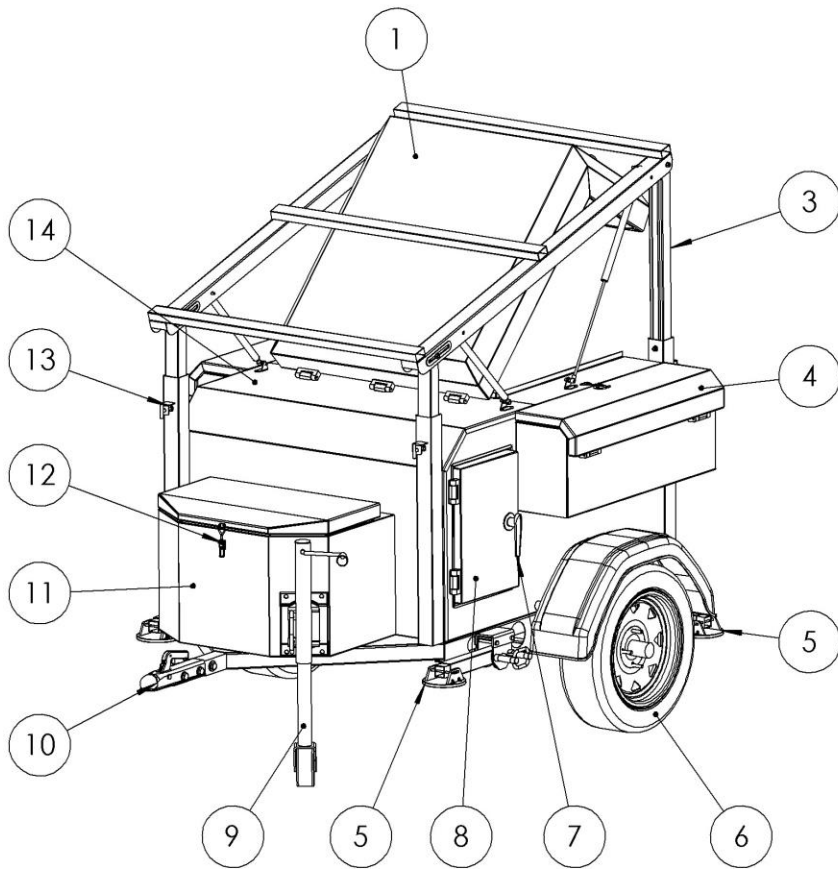

ITEM No.	DESCRIPTION
1	REAR DOOR
2	REAR DOOR HANDLE
3	LIFT FRAME
4	SIDE STORAGE BOX
5	STABILIZER LEG
6	WHEEL
7	SIDE DOOR LATCH
8	SIDE DOOR
9	JOCKEY WHEEL
10	TOW HITCH
11	FRONT BOX
12	FRONT BOX LATCH
13	LIFT FRAME ADJUSTMENT
14	MAIN STORAGE BOX
15	BACK DOOR
16	BACK DOOR LATCH
17	TAIL LIGHT
18	NUMBER PLATE LIGHT

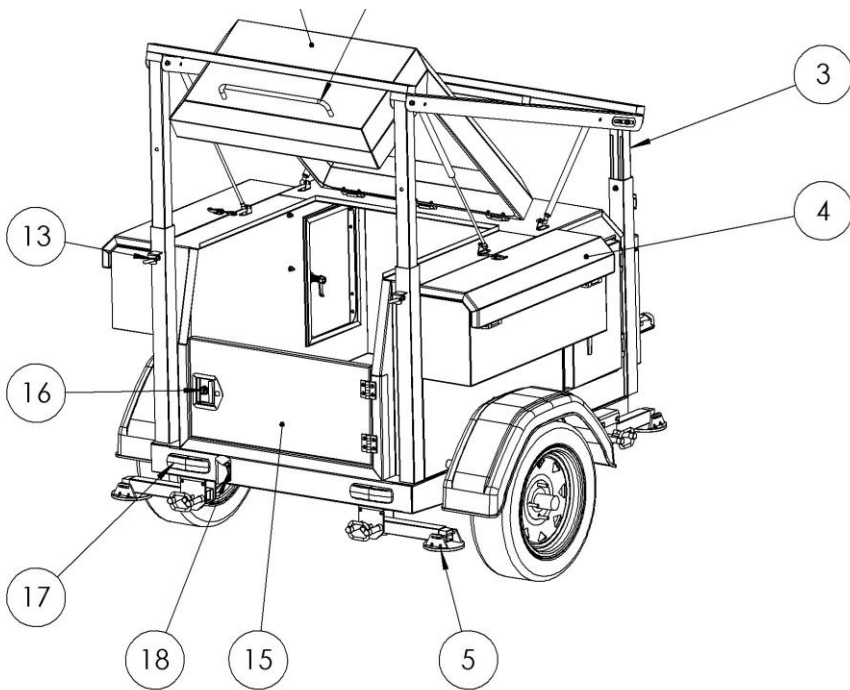

1. Towing:

- a. Ensure the Tow-ball is clean and secure to the vehicle
 - b. Hitch the RWC coupling to the tow-ball, ensure the coupling handle rests in the lowered position.
 - c. Securely fasten the Safety Chain to the vehicle, use load rated D- shackle.
 - d. Connect the 7 Pin Trailer Plug to the vehicle socket and check that all lights are functioning with the corresponding signal
 - e. After connecting trailer to vehicle following the steps above and before towing, raise all Stabiliser Feet and raise the Jockey Wheel
2. The RWC is designed to be light-weight and easily shifted into camping spots with the jockey wheel lowered. Un-hitch your RWC to shift into difficult to access camping spots or for storage.
3. All RWC are installed with a gas strut supported Lift Frame, it is designed to assist in the safe raising and lowering of items attached to the Lift Frame. Items such as Roof Top Tents come in different sizes and weights and gas struts of different force can be used to suit these specific products. Ensure the product attached to the Lift Frame matches the lifting force of the gas struts installed.
- Gas strut load rating guide:
- a. Up to 65kg – 300Nm
 - b. 66kg–100kg – 500Nm
4. Always lower the Lift Frame and secure the Locking Pins and Thumb Screws before climbing in, and for sleeping in a Roof Top Tent. Image below shows Lift Frame in lowered position.

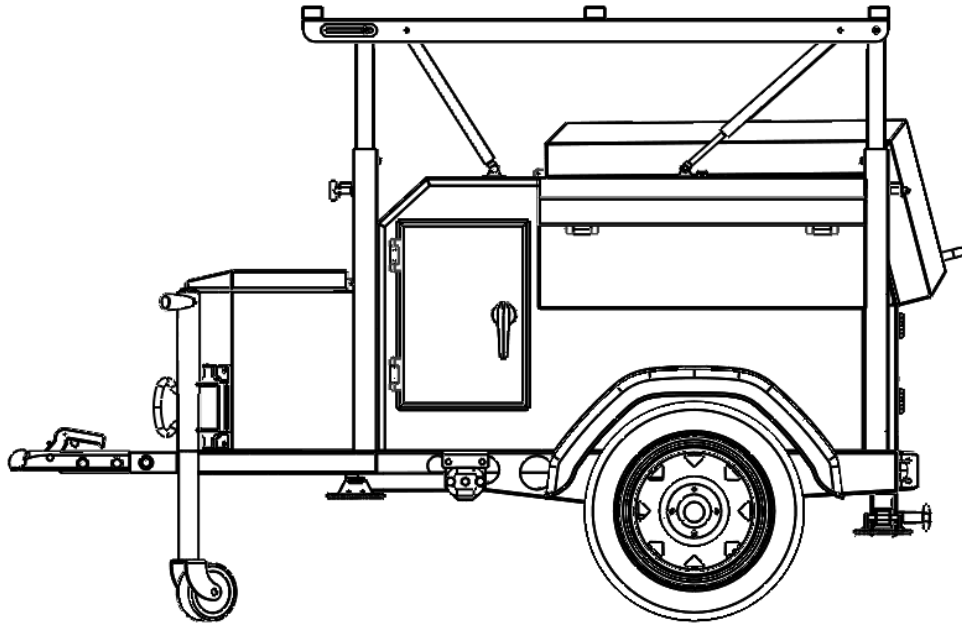

5. Ensure all doors and lids are securely fastened closed when towing.
6. When elevating the Lift Frame to the raised position start at the front and secure the lock pins and thumb screws before elevating the rear of the Lift Frame.
7. For short-term access to the cargo area of the Main Box raise the rear of the Lift Frame and return to the lowered position.
8. When raising and lowering the Stabilising Feet ensure the trailer is level, and on flat and sturdy ground. Please note the Stabiliser Feet are not recommended to be used as a jack or as a means of lifting the RWC Trailer. Do not over-extend or over-tighten the Stabiliser Feet.
 - a. Use the handle to change the angle of the stabilising feet and turn the Adjustment Pin.

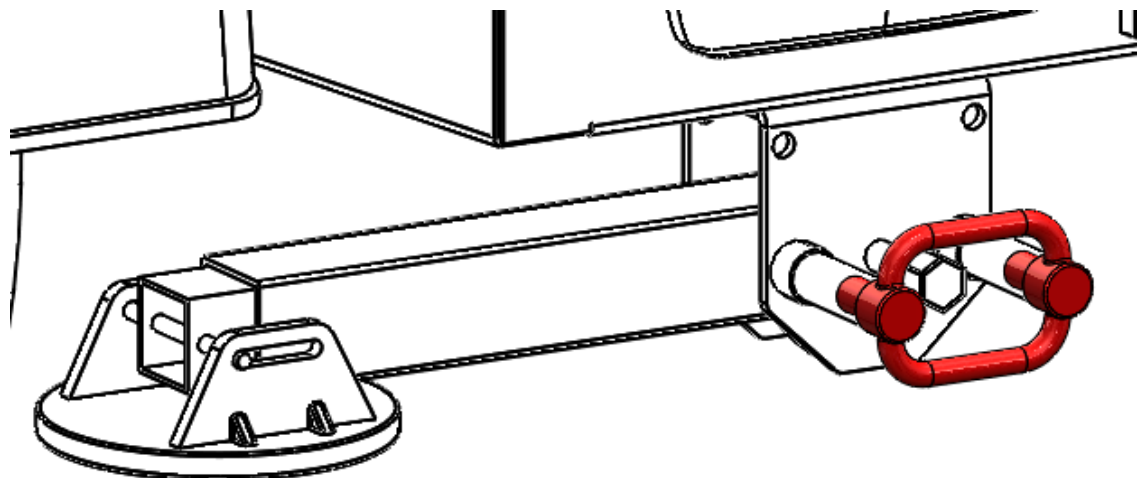

- b. Use a 19mm socket to extend and retract the Stabilising Feet. If using a power tool, use low speed to avoid damage to the mechanism. All Stabiliser Feet should just rest on the ground surface. Do not over-extend or over-tighten.

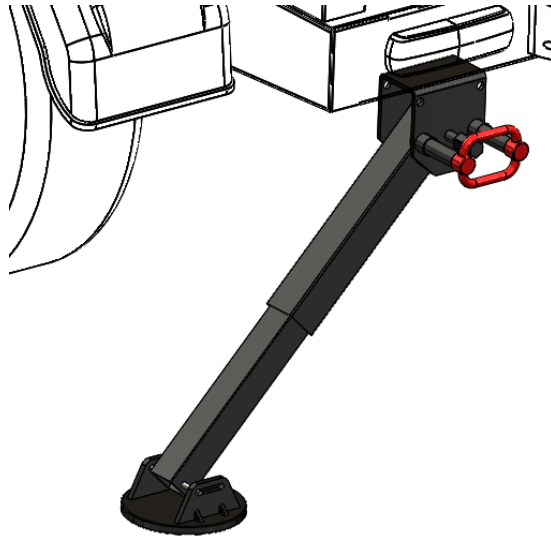

MAINTENANCE:

1. Inspect trailer bearings regularly, service every 10,000kms and or every year.
2. Apply grease to the tow ball every 500 kilometres or when the tow ball / coupling is dry.
3. Check all threaded fasteners regularly, ensure they are secure.
4. Check that tyres have sufficient tread and are properly inflated as per the tyre rating.
5. Check all door seals regularly to prevent ingress form dust and weather
6. Check that door handles properly engage the jam and provide sufficient closing force to clamp and seal the door. Door handles and mechanisms are easily adjusted: use a spanner to adjust the rotating or over centre toggle.
7. Do not rest the trailer coupling on the ground, always use the jockey wheel to prevent damage.
8. Store the RWC camper under cover to prevent weather damage.

**FOLLOW US ON FACEBOOK AND
INSTAGRAM TO SEE WHAT WE'RE UP TO!**



Check out our website at <https://www.roadwarriorcampers.com.au/>

ROAD WARRIOR CAMPERS

Impact Import Grp Pty Ltd.

Rear of 153 Ash Road

Leopold VIC 3224

Australia

Email: sales@roadwarriorcampers.com.au

Photographs and diagrams are for illustration purposes only. Actual product may vary, and any specifications are subject to change without prior notice.

Issue No: 05

Revision Table - Do not Print on Customer Copy

Revision	Description	Location	Author	Date
01	Draft for Review, Diagrams added,		GM, MS	20220712
02	Updates and Images added		GM	20220712
03	Release for PDF		GM	20220712
04	Update ATM, Shift Safety warnings to front paragraph, add VIN image		GM	20220715
05	VIN Plate Image Removed		GM	20230719